

KJ4000LW

Operating Instructions

& Parts Manual

NSN



Mandus Group Ltd.

KJ4000LW Operators Manual

Date: 1 Oct. 2004

TABLE OF CONTENTS

General Safety Instructions	Page 1
Operator Instructions	Page 2
KJ4000LW Oil Transfer System Parts List	Page 3
KJ4042 Reservoir Fill Line Operator Instructions	Page 5
KJ4043 Recirculation Kit Operator Instructions	Page 8
KJ4044 Flow Meter and Gage Kit	Page 10
Trouble Shooting Procedures	Page 11
KJ4000LW Option Product List	Page 12
KJ1000 Information Data.....	Page 13
KJ1000 Option Product List	Page 14
Warranty Information	Page 15



GENERAL SAFETY INFORMATION

1. **DO NOT** operate the KJ4000LW or any of its components without first reading and understanding all the operating instructions first.
2. **DO NOT** operate the KJ4000LW unless the oil level in the reservoir is at least one inch from the bottom of the sight glass.
3. **DO NOT** operate the KJ4000LW at temperatures greater than 110 degrees F or less than -20 degrees F.
4. **DO NOT** operate the KJ4000LW on less than a 20 amp service.
5. **DO NOT** attempt to apply more than 2500 psi anywhere to the KJ4000LW.
6. **DO NOT** attempt to lift the KJ4000LW with less than two men. The KJ4000LW weighs approx. 145 lbs.
7. **DO NOT** attempt to use the KJ4000LW and its accessories in any way other than their intended use.

GENERAL MAINTENANCE INFORMATION

1. Inspect all oil lines and connections twice a year for any cracks, leaks, or excessive wear.
2. Change oil filter every year or when the red indicator on filter head is present, whichever comes first.
3. Inspect electric cord once a year for any excessive wear, cracks, or exposed wires.
4. Replace KJ4044 display face unit every four years. Remove unit by removing 3 screws located around the side of face unit and lift straight off.
5. Use the hand pump at least twice yearly. Connect the KJ4000LW to the gun, in accordance with the manual, and shift the valve to the 'To Gun' position. Manually pump the hand pump approx. 20 or 30 times or until you can see the reserve indicator move. Shift valve back to the 'Neutral' position and remove the KJ4000LW, in accordance with the manual.

WARNING! Please read and save these instructions. Read carefully before attempting to assemble, install, operate or maintain the product described. Protect yourself and others by observing all safety information. Failure to comply with instructions could result in personal injury and/or property damage! Retain instructions for future reference.



KJ4000LW Oil Transfer System

Mandus Group Ltd.
P.O. Box 214
101 Edgewood Lane
Long Grove, IA 52756
1-888-922-8502
www.mandusgroup.com

Description

The KJ4000LW provides .59 GPM of oil flow for ease in filling oil reservoirs, as well as recoil mechanisms, buffers, and replenishers. The KJ4000LW can provide oil pressure up to 2500 PSI. The KJ4000LW is engineered to self-purge the system and lines of air prior to pumping oil. The KJ4000LW accepts and discharges oil from and to pressurized systems through the same line by means of an innovative design. This design allows oil to flow through a 5-micron, high-pressure filter in either direction, whether it is from a pressurized system or from the reservoir. The KJ4000LW has a manual back-up handpump that pumps .7 cubic inches per cycle.

Unpacking KJ4000LW

When unpacking the KJ4000LW, inspect for any loose, missing, or damaged parts. Notify Mandus Group Ltd. as soon as possible if missing or damaged parts are found. Add oil to your desired level in the oil tank prior to operating the KJ4000LW.

General Safety Information

- DO NOT operate the KJ4000LW without reading and understanding all the operating instructions first.
- DO NOT operate the KJ4000LW unless the oil level in the reservoir is at least one inch from the bottom of the sight gauge.
- DO NOT operate the KJ4000LW at temperatures higher than 110 deg. F or less than -20 deg. F.
- DO NOT operate the KJ4000LW on less than a 20-amp service.

Set-up and Operation

NOTE: These operating instructions are for any application, but tailored for the M198 Howitzer. For answers to specific questions on any applications contact Mandus Group Ltd.

To Fill

- Connect the female quick connect (101) on the 15 ft. discharge line (94) with the male quick connect (32) just above the pump and under the valve (26).
- Attach the other end of the 15 ft. discharge line (94)(101) with the male quick connect (65) at rear of the KJ4000LW and in the upper right corner. This is the purge station.
- Make sure the valve handle (26) is in the neutral position.
- Make sure the switch on the right rear of the motor is in the off position (16).
- Plug the KJ4000LW power cord into a 20-amp service.
- Turn pump on (16), shift valve handle (26) to the "to gun" position.
- Run pump for about 20 to 30 seconds to clear any air from the lines.
- Shift valve handle (26) to the "neutral" position.
- Turn pump off (16).

*The adapter on the end of the 2 ft. discharge line (95) is threaded with a .625-18 UNF-2A thread. The standard adapter shipped is intended for the oil releasing tool for the 198 Howitzer. Contact Mandus Group Ltd. for adapters for other applications.

- Disconnect discharge line (94) from purge station (65).
- Attach the oil-releasing tool (not supplied) to the end of the 2-ft. discharge line (95), making sure the washer seal (99) is in place in the connector (100). Tighten hand tight.
- Make sure the shut-off valve (98) on the 2-ft. discharge line (95) is off. Insert oil releasing tool into oil port being serviced and tighten with wrench.
- Connect the quick connects on the 2-ft. (95) and 15 ft. (94) discharge lines.
- Make sure the valve handle (26) is in the "neutral" position.
- Turn valve (98) on the 2-ft. discharge line (95) on.
- Turn switch (16) "on".
- Shift the valve handle (26) to the "to gun" position until the oil level in the pressurized system is at a desired level.
- When the oil level is at the desired level, shift valve handle (26) to the neutral position.
- Shut pump off.
- Turn the valve (98) on the 2-ft. discharge line (95) off.
- Shift the valve handle (26) to the "from gun" position to the "to gun" position and then to the "neutral" position. This relieves any line pressure.

To Drain

Refer to steps 11, 12 and 13 before proceeding.

- To drain a pressurized oil vessel, shift the valve handle (26) to the "from gun" position and open shut-off valve (98) until the oil level in the pressurized vessel is at the desired level.
- Shift valve handle (26) to the "neutral" position.
- Repeat step 21.
- Disconnect oil lines (94) (95).
- Task complete.

Operation of Manual Pump

- See Set-up and Operations, Steps 1 through 25. Disregard any instructions using the electric motor and power cords.
- Whenever the instructions state "turn motor on," insert the pump handle (107) into the pump (87) and start pumping.
- Always remove pump handle when pumping is completed.

Changing Oil Filter

Mandus Group Ltd. recommends changing the filter element annually.

- When the indicator on the top of the oil filter (37) does not show green, the oil filter needs to be changed.
- Unscrew the canister on the bottom of the oil filter and remove the filter.
- Replace the filter (106) with part number OP20030.
- Reinstall the canister and follow the purging instructions described in the Set-up and Operation section.

KJ4000LW Parts List

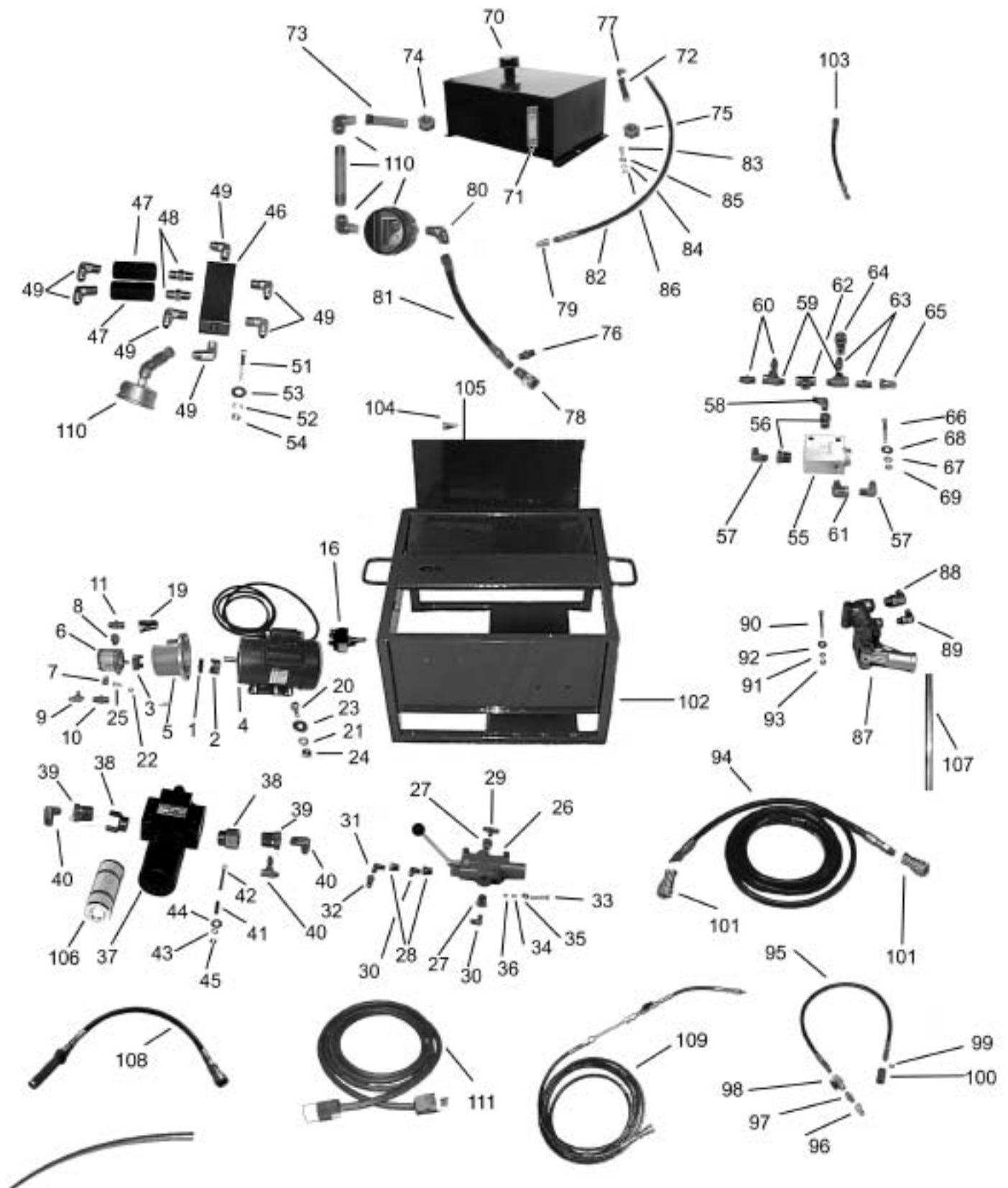

Repair Parts List

Ref Number	Description	Part Number	Qty	Ref Number	Description	Part Number	Qty
1	Spider	9921010	1	58	Male Elbow	9925040	1
2	5/8 Coupler	9921030	1	59	Male Tee	9925050	2
3	1/2 Coupler	9921020	1	60	Male Connector	9925060	2
4	Motor	9921040	1	61	Street Elbow	9925065	1
5	Bell Housing	9921050	1	62	Female Tee	9925070	1
6	Pump	9921060	1	63	Nipple	9925080	2
7	Adaptor	9921070	1	64	Female Quick Connect	9925090	1
8	Adaptor	9921080	1	65	Male Quick Connect	9925100	1
9	Female Tee	9921090	1	66	Bolt	BK00150	2
10	Nipple	9921100	1	67	Lock Washer	BK00170	2
11	Nipple	9921110	1	68	Flat Washer	BK00180	2
16	Switch	9921160	1	69	Nut	BK00160	2
19	Male Quick Connect	9921170	1	70	Reservoir	9926010LW	1
20	Bolt	BK00010	4	71	Sight Glass	9926020	1
21	Lock Washer	BK00050	4	72	Suction Strainer	9926030	1
22	Lock Washer	BK00170	2	73	Suction Strainer	9926040	1
23	Flat Washer	BK00060	4	74	Pipe Thread Reducer	9926050	1
24	Nut	BK00040	4	75	Reducer	9926055	1
25	Bolt	BK00140	2	76	Male Connector	9926057	1
26	Valve	9922010	1	77	Elbow Adaptor	9926060	1
27	Reducer	9922020	2	78	Female Quick Connect	9926080	1
28	Reducer	9922030	2	79	Male Quick Connect	9926090	1
29	Male Tee	9922040	1	80	Elbow Adaptor	9926100	1
30	Elbow Adaptor	9922050	2	81	Hose	HA100400	1
31	Male Elbow	9922060	1	82	Hose	HA100300	1
32	Male Quick Connect	9922080	1	83	Bolt	BK00140	2
33	Bolt	BK00030	3	84	Lock Washer	BK00170	2
34	Lock Washer	BK00050	3	85	Flat Washer	BK00180	2
35	Flat Washer	BK00060	12	86	Nut	BK00160	2
36	Nut	BK00040	3	87	Hand Pump	9927010	1
37	Filter	9923010	1	88	Fitting	9927020	1
38	Adaptor	9923030	2	89	Fitting	9927030	1
39	Reducer	9923035	2	90	Bolt	BK00080	2
40	Nipple Adaptor	9923040	2	91	Lock Washer	BK00120	2
41	Spacer Tubes	9923050	2	92	Flat Washer	BK00130	2
42	Bolt	BK00100	2	93	Nut	BK00110	2
43	Lock Washer	BK00120	2	94	Hose	HA100200	1
44	Flat Washer	BK00130	2	95	Hose	HA100900	1
45	Nut	BK00110	2	96	Male Quick Connect	9928020	1
46	Manifold	9924010	1	97	Nipple	9928030	1
47	Check Valve	9924020	2	98	Valve	9928040	1
48	Nipple	9924030	2	99	Adaptor Seal	9928050	1
49	Elbow Adaptor	9924040	7	100	Adaptor	9928060	1
51	Bolt	BK00075	2	101	Female Quick Connect	9928070	2
52	Lock Washer	BK00120	2	102	Frame	9920010	1
53	Flat Washer	BK00130	2	103	Hose	HA100100	10
54	Nut	BK00110	2	104	Self Tap Screw	BK00310	12
55	Pilot Operated Check Valve	9925010	1	105	Frame Side Panel	9920020	2
56	Reducer	9925020	2	106	Filter Element	0P20030	1
57	Elbow Adaptor	9925030	2	107	Pump Handle	9927040	1
				108	Reservoir Fill Line	KJ4042	1
				109	Recirculation Kit	KJ4043	1
				110	Flow Meter & Gage	KJ4044	1
				111	25 Foot Extention Cord	400077LW	1



INSTALLATION AND USER INSTRUCTIONS FOR THE KJ4042 RESERVOIR FILL LINE.

NOTE!!!

Make sure that the KJ4000LW is disconnected from the electrical source and there is no pressure in the lines. To relieve pressure shift valve handle to the "TO GUN" and then to the "FROM GUN" positions and then back to "NEUTRAL".

1. Inspect the KJ4042 Reservoir Fill Line to make sure it was not damaged during shipment. (See figure A)



Figure A

2. Disconnect the inlet quick connect at the pump. This is the only quick connect at the pump and it is located at the left side of pump while looking at the KJ4000LW from the pump side.
3. Feed the quick connect end of the reservoir fill line thru the top of the KJ4000LW left of the shift lever (see figure B).

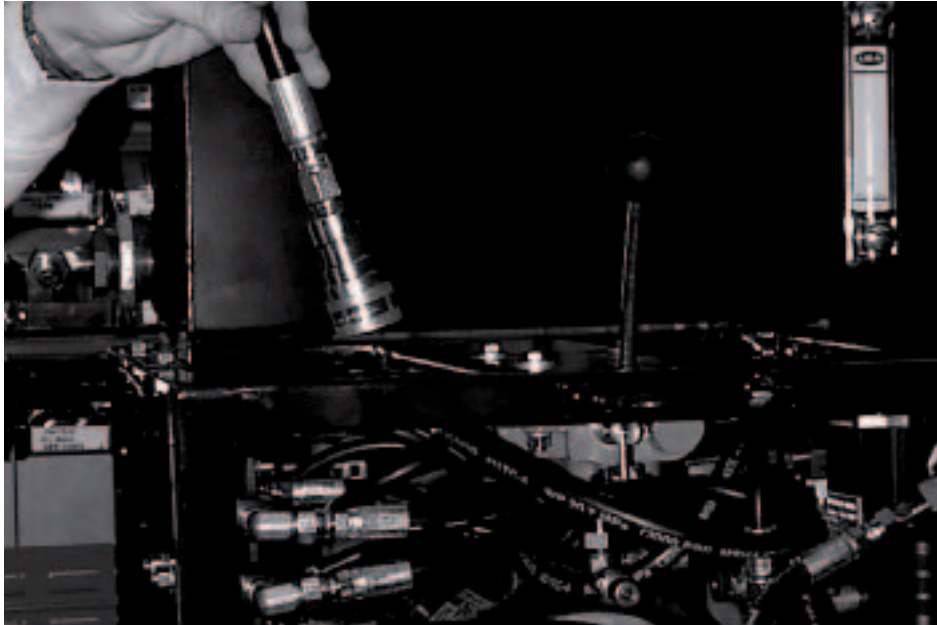

Figure B

4. Couple the reservoir fill line quick connect to the quick connect on the pump.
5. On the suction end of the reservoir fill line, you will notice a suction strainer (see figure C). Place the strainer end of the reservoir fill line into your oil supply.

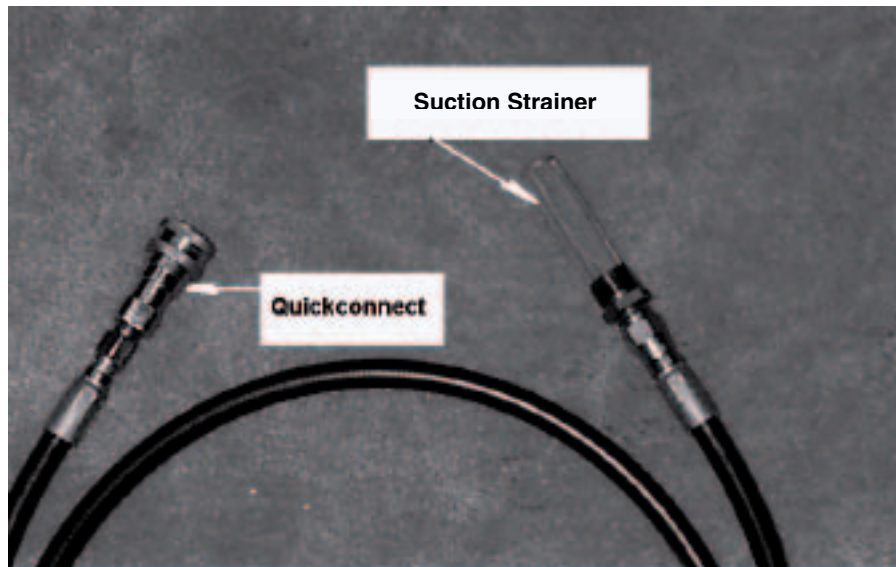

Figure C

NOTE!!! Reservoir Fill Line should be used with clean oil. Make sure suction strainer is all the way to the bottom of the oil supply container.

6. Connect the KJ4000LW to your power source. With the valve in the “NEUTRAL” position, turn the KJ4000LW on.

IMPORTANT!!!

Reservoir fill line must be used with the KJ4000LW valve shift lever in the neutral position!!!

NOTE!!!

There will be residual oil in the bottom of the sight glass that is trapped. This oil is from the testing done on the KJ4000LW prior to shipping. A visible oil level in sight glass refers to 1 inch or higher.

7. If oil level is already visible in the KJ4000LW sight glass, you should be able to see the oil level rising shortly after turning on the pump. If oil level is not visible in sight glass, you should notice the oil starting to rise within 3 to 4 minutes. If you don't see oil starting to rise within 3 to 4 minutes, shut KJ4000LW off and contact Mandus Group Ltd.
8. Fill reservoir to desired level. Keep an eye on the source oil supply so you don't run the KJ4000LW dry. Running dry for more than 4 minutes could damage the pump.
9. When finished, turn pump off and disconnect from power source. Relieve any line pressure as described earlier.
10. Disconnect the Reservoir Fill Line from the pump and reconnected the KJ4000LW reservoir line to the pump.

NOTE!!!

The KJ4042 Reservoir Fill Line will drip oil from suction strainer end. Care should be taken as to how and where it is stored.



INSTRUCTIONS FOR INSTALLING AND USING THE KJ4043 - RECIRCULATION KIT

- 1). Inspect the Recirculation Kit for any damage during shipment. Contact Mandus Group Ltd. if any damage is noticed.

NOTE!!!

The standard adaptor shipped with the KJ4043 Recirculation Kit has a .3125 – 24 UNF – 3A thread on it. It is intended for use with a 198 Howitzer. Contact Mandus Group Ltd. for adaptors for other equipment.

DANGER!!!

Make certain there is no pressure on recoil mechanism being serviced prior to removing port plug on the recoil mechanism.

- 2). The rubber ring seal inside the ports on the recoil mechanism of the 198 must be removed prior to assembling the adaptor to the port. Connect the adaptor end of the Recirculation Kit to the proper port on your equipment. Finger tighten only.
- 3). Connect the female quick connect end of the Recirculation Kit to the purge port on the KJ4000LW. (See figure A).

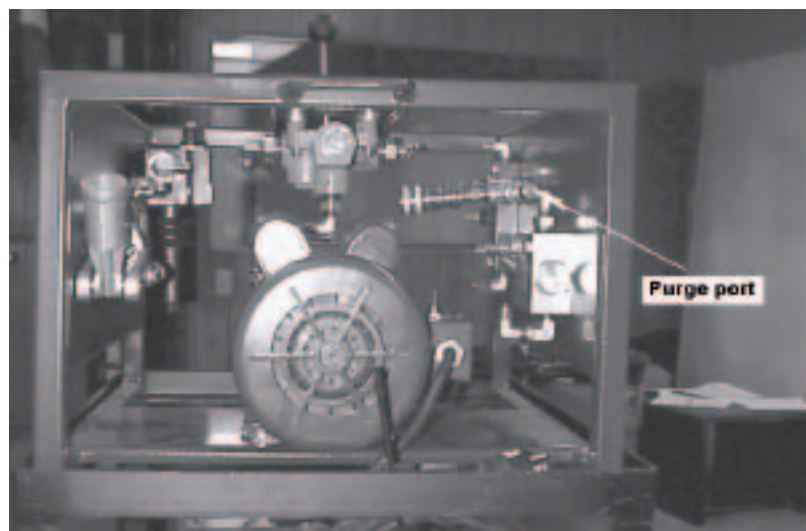

Figure A

- 4). Attach the KJ4000LW discharge hose to the recoil mechanism as described in the KJ4000LW Instruction Manual, under the set-up and operation to fill section, steps 11 thru 15.

Note!!!

Reservoir should be 3/4 full before using the KJ4043 Recirculation Kit.

Note!!!

Shut off valve on the KJ4043 Recirculation Kit should always be in the open position during operation unless you are building reserves on the replenisher.

- 5). Make sure that the valve shift lever is in the “Neutral” position.
- 6). Turn the KJ4000LW on and shift the valve lever to the “To Gun” position.
- 7). Notice the site glass during operation to ensure that the reservoir doesn’t fill and overflow. (If everything is hooked up properly, the oil level should remain constant.)
- 8). The KJ4000LW moves approximately .59 GPM of oil. You need to calculate how many times you want to turn the oil over in your system based off its volume.
- 9). When finished, shift the valve lever to the “Neutral” position and turn the KJ4000LW off. Disconnect all lines.

NOTE!!!

The KJ4043 Recirculation Kit will drip oil after removing it from system. Take care to store it in a place where it can drain.



INSTRUCTIONS FOR USING THE KJ4044 – FLOWMETER AND GAGE KIT

NOTE!!!

Always make certain that the reservoir has oil in the sight glass prior to using the meter unit. The meter will also show the volume of air that passes through it. If you run the oil in the tank below the sight glass, you would not be able to tell if you were moving oil or air through the meter!

- 1). By depressing the reset button (see figure A) for approximately 2 seconds you can zero out the meter. The pump must be off when doing this. Meters are preset at the factory to display in quarts. If you prefer liters or gallons contact Mandus Group Ltd.



Figure A

- 2). The total button will show total amount of oil moved when depressed momentarily. It cannot be cleared back to zero.

NOTE!!!

The meter will track volume when the KJ4000LW is running with the valve in the "Neutral" position. You must make sure that the KJ4000LW is setup and ready to move oil with valve in the "To Gun" position prior to turning the KJ4000LW on!

- 3). When you are ready to track the volume of oil being moved, make sure that the KJ4000LW is off and the valve shift lever is in the "To Gun" position.
- 4). Turn the KJ4000LW on. When you have reached the desired volume, shift the valve to the "Neutral" position and turn the KJ4000LW off or you can just turn the KJ4000LW off and then shift to "Neutral".

NOTE!!! If you shift to "Neutral" before turning the KJ4000LW off, your volume will continue to increase on the display.

Trouble Shooting the KJ4000LW & Accessories

Problem

Possible Solution

- | | |
|--|---|
| 1. KJ4000LW won't turn on. | 1. Circuit Breaker off in control panel.
2. Not plugged in. |
| 2. Oil won't pump to gun. | 1. "To gun-from gun" valve in wrong position.
2. Valve on the 2-foot discharge hose is in the off position.
3. Oil releasing tool not fully engaged or is clogged. |
| 3. Oil won't return from gun. | 1. "To gun-from gun" valve in wrong position.
2. Valve on the 2-foot discharge hose is in the off position.
3. Oil releasing tool not fully engaged or is clogged. |
| 4. KJ4042 won't fill reservoir. | 1. Kink in inlet line.
2. Obstruction in inlet line.
3. Suction strainer not fully submerged in oil.
4. "To gun-from gun" shift lever not in neutral position.
5. Quick connect on reservoir fill line not connected to inlet side of pump. |
| 5. KJ 4043 won't move oil from gun. | 1. "To gun-from gun" shift lever not in neutral position.
2. Rubber seal in the port on recoil mechanism not removed.
3. Valve on KJ4043 is in off position.
4. Adapter or line on KJ4043 is clogged. |
| 6. KJ4044 doesn't show accurate flow. | 1. Reservoir doesn't have enough oil and you are showing air volume.
2. Inlet line from meter to pump not connected. |
| 7. KJ4044 flow meter display is blank. | 1. Press reset button
2. Batteries are dead. Contact Mandus Group LTD for replacement parts. |

KJ4000 & KJ4000LW Oil Transfer System

OPTIONAL PRODUCTS LIST

<u>Product Number</u>	<u>Product Description</u>
KJ1045	System Cart - 5" High
KJ1046	System Cart - 32" High
KJ4041	Oil Releasing Tool
KJ4042	Reservoir Fill Line
KJ4043	Recirculation Kit
KJ4044	Flow Meter & Gage Kit



KJ4042 Reservoir Fill Line – For use with the KJ4000. Quick couples with the pump for easy loading of oil to reservoir from a can, barrel or bucket.



KJ4041 Oil Releasing Tool – For use with the KJ4000 Oil Transfer System to fill or drain the recuperator on the 198 Howitzer. Made of stainless steel.



KJ1045 5" Cart – For use with the KJ4000 Oil Transfer System or KJ1000 Nitrogen Intensifier.



KJ1046 32" Cart – For use with the KJ4000 Oil Transfer System or KJ1000 Nitrogen Intensifier.



KJ4043 Recirculation Kit – For use with the KJ4000. Used to recirculate oil through the recoil mechanism of a variety of weapon systems.



KJ4044 Flow Meter & Gage Kit – For use with the KJ4000 Oil Transfer System to determine how much oil is flowing through the KJ4000 and into the receiving system. The gage will determine how much pressure is in the system while transferring oil.



To Order Call 1-888-922-8502



Mandus Group Ltd.
P.O. Box 214
101 Edgewood Lane
Long Grove, IA 52756
1-888-922-8502
www.mandusgroup.com

KJ1000 Nitrogen Intensifier

NSN 1025-01-473-8886



The KJ1000 Nitrogen Intensifier was developed to assist the military in filling recoil mechanisms, equilibrators, or any other nitrogen filled vessel. The KJ1000 is designed to utilize and intensify all but 150 PSI of nitrogen from a supply bottle. The KJ1000 accepts the nitrogen from a supply source, then intensifies the nitrogen source pressure by means of a hydraulic pump and electric motor. The intensified nitrogen is then forced into an accepting nitrogen vessel. The KJ1000 is engineered to shut down when 150 PSI or less is left in the supply bottle, or when the customer desired factory set upper level pressure is obtained (max. for the KJ1000 is 2500 PSI).

- KJ1000 maximum operating pressure 2500 PSI
- Increases productivity
- Uses all but 150 PSI of nitrogen in supply bottle
- Requires 20 AMP electrical service
- Built in pressure gage
- Quick disconnects for all hoses and fittings
- 15 foot nitrogen hose
- 1/4 NPT male quick disconnect supplied for customer hose from nitrogen regulator
- Hand held ON/OFF pendant switch
- No contamination to nitrogen
- Size 20" W X 23 1/2" D X 15" H
- Weight 170 lbs.
- 1 Year Warranty

Available Options

- Higher pressure system can be developed upon request

Mandus Group Ltd.
P.O. Box 214
101 Edgewood Lane
Long Grove, IA 52756



Toll-Free (888) 922-8502
www.mandusgroup.com

KJ1000
Nitrogen Intensifier
OPTIONAL PRODUCTS LIST

<u>Product Number</u>	<u>Product Description</u>
KJ1045	System Cart - 5' High
KJ1046	System Cart - 32' High
KJ1041	Gage Set
KJ1042	Crossover Line
KJ1043	Nitrogen Discharge Hose
KJ1044	Tank Fill Stem
KJ1047	Tank Regulator Set
KJ1048	Nitrogen Extraction Kit

See next page for photos and product descriptions.



To Order Call 1-888-922-8502



Mandus Group Ltd.
P.O. Box 214
101 Edgewood Lane
Long Grove, IA 52756
1-888-922-8502
www.mandusgroup.com



KJ1046 32" Cart – For use with the KJ4000 Oil Transfer System or KJ1000 Nitrogen Intensifier.



KJ1047 Tank Regulator Set – For use with 2000 PSI nitrogen tanks. Delivery range 0 to 2500 PSI. Comes with 15 ft. discharge hose to couple up with KJ1000.



KJ1041 Gage Set – For checking and bleeding nitrogen pressure in equilibrators and recuperators on the 198 Howitzer.



KJ1045 5" Cart – For use with the KJ4000 Oil Transfer System or KJ1000 Nitrogen Intensifier.



KJ1043 Nitrogen Discharge Hose – For use with the KJ1000 Nitrogen Intensifier and KJ1042 Crossover Line or to be used with the KJ1000 Nitrogen Intensifier and the KJ1044 Tank Fill Stem.



KJ1044 Tank Fill Stem – For use with the KJ1000 Nitrogen Intensifier and the KJ1043 Nitrogen Discharge Hose. The tank fill stem allows consolidation of low pressure nitrogen bottles into one tank at pressures from 0 to 2500 PSI.



KJ1048 Nitrogen Extraction Kit – For use with the KJ1000. Used to extract and purify nitrogen coming from a M198 Howitzer equilibrators or recuperator and placing it in a 2000 PSI nitrogen bottle.



KJ1042 Crossover Line – To be used with the KJ1000 Nitrogen Intensifier to fill equilibrators on a 198 Howitzer. Can couple up with the standard discharge hose on the KJ1000 or the KJ1043 Nitrogen Discharge Hose.

Mandus Group Ltd. Manufacturer's Limited Warranty

For one year from date of purchase, Mandus Group Ltd. will repair or replace, at its expense and at its option, any KJ4000LW machine part, or machine accessory which in normal use has proven to be defective in workmanship or material, provided that the customer returns the product prepaid to Mandus Group Ltd.'s repair service center and provides Mandus Group Ltd. with reasonable opportunity to verify the defects by inspection. Mandus Group Ltd. will not be responsible for any asserted defect which has resulted from normal wear, misuse, abuse or repair or alteration made or specifical-

ly authorized by anyone other than an authorized Mandus Group Ltd. service facility or representative. Under no circumstances will Mandus Group Ltd. be liable for incidental or consequential damages resulting from defective products. This warranty is Mandus Group's sole warranty and sets forth the customer exclusive remedy, with respect to defective products. All other warranties, expressed or implied, whether of merchantability, fitness of purpose, or otherwise, are expressly disclaimed by Mandus Group Ltd.