

MG1100 Manual

NSN MG1100 3655-01-544-2362



Mandus**Group**

SAFETY INSTRUCTIONS

SUMMARY:

The following are general safety precautions that are not related to any specific procedures and therefore do not appear elsewhere in this manual. These are general safety precautions that operators and maintenance personnel must understand and apply during many phases of operation and maintenance to ensure personal safety and protection of the equipment.

Throughout this manual, three types of notations are provided which contain special information:

NOTE: Provides additional information that may be helpful in performing a specific task.

CAUTION: Provides information about conditions which require special attention and precautions to avoid serious or fatal injuries.

WARNING: Provides information about conditions which require special attention and precautions to avoid serious or fatal injuries.

GUIDELINES FOR HANDLING COMPRESSED GAS CYLINDERS

- Nitrogen cylinders are under extremely high pressure (up to 2500psi) and present a number of associated hazards as a result.
- The sudden release of the cylinder pressure, whether by puncture, damage to a valve caused by dropping or other means can turn the cylinder into a missile which can travel along the ground or through the air at high speeds. Take extreme care when filling and handling charged cylinders.
- Do not drag or slide the cylinders by the pressure cap, this may cause the sudden release of cylinder pressure. Use a suitable hand truck, fork lift or similar device for handling large cylinders.
- Do not drop cylinders or permit them to strike against each other or other surfaces, this may cause the sudden release of pressure. Securely secure the cylinders during filling, storage and transport.
- Do not fill cylinders too rapidly; excessive heat may build up in the gas which could result in a failure of the cylinder valve seals and possible fire. Periodically check the surface temperature of the cylinders during charging.
- Never charge cylinders with nitrogen that are marked for other gasses. Always check the cylinder markings and ensure that only cylinders marked for nitrogen are charged with nitrogen. Do not use adapters to fill cylinders that do not have the correct fittings for nitrogen.

WARNINGS

- Improper use of this product may cause severe personal injury or death. Read and understand this manual before using or servicing this product.
- Make sure any equipment connected to the MG1100 is rated for the applicable pneumatic pressure.
- Only factory supplied assemblies may be interchanged to repair the MG1100. Interchange of parts or assemblies between MG1100 units may result in damaged parts or components and could void warranty.

CAUTIONS

- Risk of electrical shock. DO NOT remove covers. Refer servicing to qualified service personnel.
- System operation requires that the waste gas exhaust be released to the air. The operation of the MG1100 is dependent on the release of exhaust gas. Do not restrict the exhaust hose in any manner. It is recommended that no extensions be connected to the exhaust hose provided.
- Hose fittings must be leak tight. A small leak can severely impair performance of the MG1100.
- If an extension cord must be used to deliver power to the MG1100 ensure that it is adequately sized and in good repair.
- Risk of electrical shock. Refer servicing to qualified service personnel.
- Verify that panel fans are operating prior to use. Operation of compressor without fan operation may cause premature failure of MG1100.
- Shop air must be filtered and dry before making contact with the unit.

OPERATION SAFETY ISSUES

Never try to connect/disconnect fittings while under pressure. Before any operation and before connecting anything to a pressurized source, make sure to bleed lines first by opening valves "A" and "D". Do not change machine configurations while machine is running. Make sure you have a good knowledge of working with compressed gas before operating this equipment. Please make sure you read and understand this manual before attempting to operate this equipment. Make sure to visually inspect all hoses, cords, and connections before operating this equipment to make sure they are free from extreme wear or damage.

OPERATING INSTRUCTIONS

GENERAL MAINTENANCE INFORMATION

- Inspect electric cord once a year for any excessive wear, cracks, or exposed wire.
- It is the user's responsibility to obtain service for the beds after 12,000 hours.
- It is the user's responsibility to obtain service for the booster after 5,000 hours.
- Visually inspect unit for wear before using.

BASIC INFORMATION

- The MG1100SE has the onboard tank option where as the MG1100 does not.
- The MG1100 is designed to extract Nitrogen from 60-80 psi compressed shop air.
- It is the user's responsibility to make sure that the compressed shop air is filtered and dry before it reaches the unit. It is also the user's responsibility to not operate this equipment in less than 40 degree F or higher than 120 degree F ambient conditions.
- Maximum system pressure is 2500 psi.
- When the unit is first turned on, it will run for approximately 2 minutes (for generation mode only) before the booster kicks in. You may also hear a slight hiss during this 2 minute period.
- There is an alarm that will sound if purity drops below 96%.
- The unit is designed to shut off when outlet pressure reaches 2400-2500 psi. It will automatically turn back on when it drops below approximately 2100 psi.
- NOTE: When using tank by-pass option you cannot allow an uncontrolled free flow between the tanks, you must open the valve only partially to allow a slow and controlled gas flow between the tanks.

CAPABILITIES

1. Generate nitrogen, boost and transfer nitrogen to external tank/vessel.
2. Boost external nitrogen to a pressure of 2400 psi from one tank/vessel to another tank/vessel.

NOTE: It is important for the user to understand that when employing capabilities 1 and 2, you cannot achieve pressure equalization between tanks in a timely fashion without using bypass valve "B". The reason for this is flow stop points or fixed regulated pressure points within the system.

CAPABILITY 1:

Generate nitrogen, boost and transfer nitrogen to external tank/vessel.

- Slowly open bleed valves "A" and "D" to relieve any internal line pressure.
When you have bled the internal lines, close all valves "A, B, C, D, and E".
- Connect the user provided shop air quick connect and hose to the port marked "Inlet Shop Air"
- Connect the supplied outlet hose to the port marked Outlet using the quick connect fitting.
- Connect the other end of the outlet hose to the external tank/vessel.
- Plug the power cord into a 115 VAC receptacle.
- Turn switch on.

CAPABILITY 2:

Boost external nitrogen to a pressure of 2400 psi from one tank/vessel to another tank/vessel.

- Slowly open bleed valves "A" and "D" to relieve any internal line pressure. When you have bled the internal lines, close all valves "A, B, C, D, and E".
- Attach user provided quick disconnect and hose from external tank and connect to the port marked "Tank Inlet".
- Connect the provided quick disconnect and hose from the vessel/tank that is being filled to the port marked "Outlet".
- Slowly open both tank valves on the tanks you have just connected to the MG1100.
- If the supply tank contains gas at a higher pressure than the receiving tank/vessel, slowly open by pass valve "B" until both tanks have equalized in pressure. Once pressure has equalized, close by pass valve "B".
- Plug power cord into 115 VAC receptacle
- Turn the power switch on

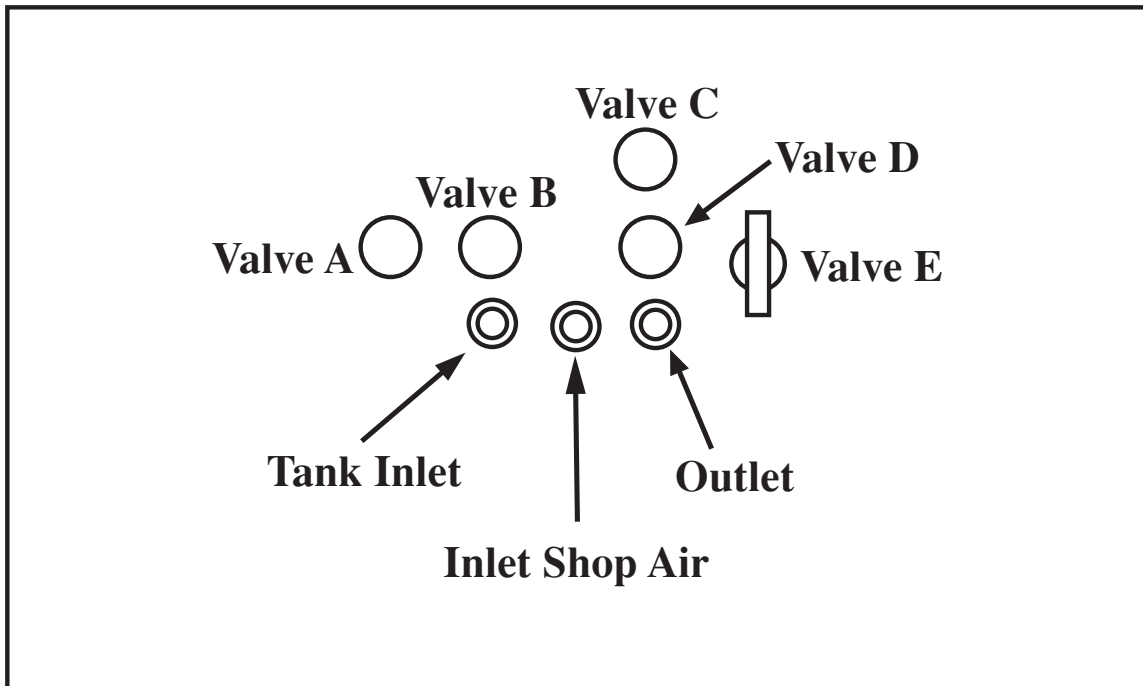

MANDUS GROUP LTD. MANUFACTURER'S LIMITED WARRANTY

For one year from date of purchase, Mandus Group Ltd. will repair or replace, at its expense and at its option, any MG1100 machine part, or machine accessory which in normal use has proven to be defective in workmanship or material, provided that the customer returns the product prepaid to Mandus Group Ltd's repair service center and provides Mandus Group Ltd with reasonable opportunity to verify the defects by inspection. Mandus Group Ltd will not be responsible for any asserted defect which has resulted from normal wear, misuse, abuse or repair or alteration made or specifically authorized by anyone other than an authorized Mandus Group Ltd service facility or representative. Under no circumstances will Mandus Group Ltd be liable for incidental or consequential damages resulting from defective products. This warranty is Mandus Group's sole warranty and sets forth the customer exclusive remedy, with respect to defective products. All other warranties, expressed or implied, wither of merchantability, fitness of purpose, or otherwise, are expressly disclaimed by Mandus Group Ltd.

NOTE: It is the user's responsibility to obtain service for the beds after 12,000 hours, and not included in the warranty.

NOTE: It is the user's responsibility to obtain service for the booster after 5,000 hours and not included in the warranty.